

MASSEY FERGUSON



75-100 Max Engine HP  
70-100 Rated Engine HP

4700 Global Series Tractors



MASSEY FERGUSON  
4700 Global Series



**FROM MASSEY FERGUSON**  
A world of experience. Working with you.

# AN INVESTMENT IN THE FUTURE OF UTILITY TRACTORS.

For more than 170 years, we've been perfecting the utility tractor. And even though more than four million of ours have shown up for work on farms and jobs like yours around the world, we're never quite satisfied.

## Introducing the Massey Ferguson® 4700 Global Series tractors.

A part of a \$350 million investment, the largest manufacturing and new product project in AGCO® history, the Global Series has been completely engineered from the ground up and built in our new state-of-the-art manufacturing facility. The Massey Ferguson 4700 Global Series tractors are the result of years of insight from farmers, contractors, operators and dealers from around the world. And they have been put through more than 65,000 hours of rigorous endurance testing in extreme weather and

terrain conditions in seven different sites around the globe. From the rice paddies of Southeast Asia to the oppressive heat of Africa to the bitter cold of Northern Europe to the grueling applications required for farming in North America, these tractors have been through it all.

These heavy-duty tractors are purpose-built for more lift capacity and the power to pull larger, heavier implements. Now—and well into the future.

**70–100 RATED ENGINE HP**—Choose a base weight of 7,125–8,644 lbs. and a lift capacity of 4,850 lbs. Plus our AGCO Power™ three-cylinder 3.3 L engine with a hydraulic flow of 17.7 GPM.





## **WE'VE NEVER BUILT TRACTORS QUITE LIKE THIS.**

The heavy-duty 4700 Global Series gives you the power, stability and versatility to handle tougher jobs so you can get more done, regardless of your operation.

- **HAY**—Whether you're mowing, tedding, raking, baling or hauling, these tractors were designed to pull bigger balers, tow bigger mower conditioners, and carry heavier bales than other tractors in their class. Plus, they match up perfectly with Hesston by Massey Ferguson® hay equipment.
- **DAIRY**—Dairy operations need a tough, do-everything tractor that can handle the heavy lifting while still being nimble and maneuverable in tight spaces. Because the days can be long, it also has to be comfortable. These are those tractors.
- **FARMS**—For farms of all sizes, these tractors are going to be your new best friend. From the field to the barn and everything in between, you'll have a stable, easy-to-operate machine that won't let you down.
- **LOADER WORK**—You've got a ton of different jobs to tend to each day, and you need a loader that can handle all of them. The heavy lift capacity is ideal for applications such as lifting, grading and snow removal. And with float mode, the loader rises and lowers to follow the contour of the ground.

# DURABILITY IS IN OUR DNA.

## Maintenance-Free Emissions System

Global Series tractors meet Tier 4 Final emissions requirements, with the use of an all-in-one SCR technology, eliminating the need for a Diesel Particulate Filter (DPF) or regeneration.

## AGCO Power™ Engines

4700 Global Series tractors feature a three-cylinder, 3.3 L AGCO Power engine, capable of generating 75 to 100 HP.

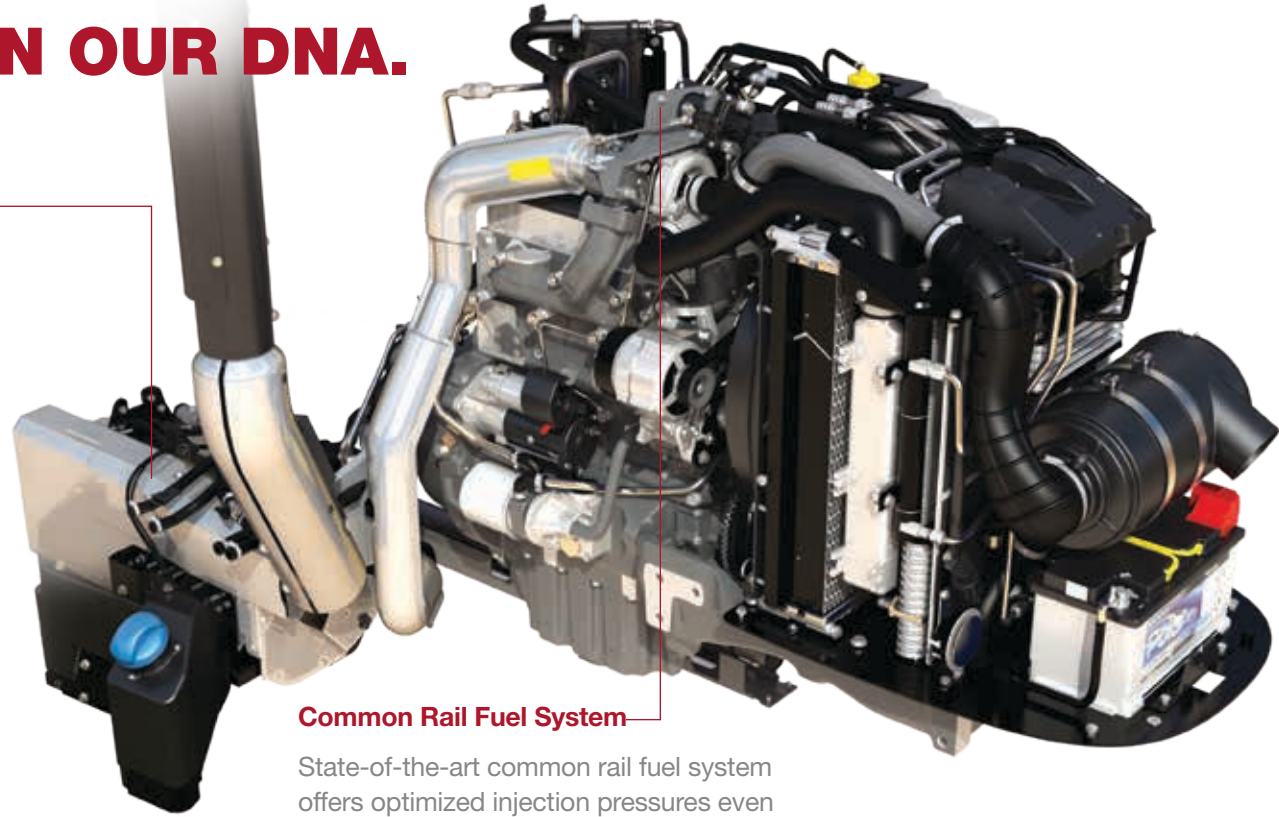

## Common Rail Fuel System

State-of-the-art common rail fuel system offers optimized injection pressures even at low engine speeds. Higher temperatures also mean no need for a DPF filter.

At the heart of it all is a rugged, reliable, fuel-efficient AGCO Power Tier 4 Final engine. These engines range from 70 to 100 horsepower and are specifically designed for North American farms, featuring a 3.3 liter three cylinder turbo-charged engine.

- **POWERFUL AND QUIET**—The turbo-charged diesel power plant delivers maximum torque at low engine speeds. You not only get clean exhaust and minimal fuel consumption but also both noise and tractor wear and tear are reduced. You enjoy an unmatched operator experience and a very comfortable cost of operation.

- **RUNS SMOOTHLY**—Four valves per cylinder improve airflow and enhance the fuel/air mixture, so you run cool and smooth hour after hour, keeping service costs low.
- **INTELLIGENCE INSIDE**—The AGCO Power engine-management system monitors every aspect of the engine's operation, automatically adjusting fuel flow, injection timing and other functions to deliver consistently outstanding performance and low fuel consumption.
- **NO NEED FOR A DPF**—These tractors don't require a diesel particulate filter (DPF). It's still environmentally friendly while saving you money, time and fuel.

# EASY-TO-OPERATE AND EFFICIENT 12 x 12 TRANSMISSION

The MF 4700 Global Series tractors feature a synchronized transmission that provides a total of twelve forward and twelve reverse speeds courtesy of two ranges. Six gears are within the 2.4–7.5 MPH typical fieldwork range, while maximum speed is 25 MPH.



The right speed for each job is conveniently selected using gear levers that are within easy reach, yet positioned neatly to the driver's hand, ensuring an unimpeded passage when mounting/dismounting. A single-plate, wet clutch is easy to operate and simple to service. Super Creeper option is also available when the lowest speeds, down to .08 MPH\*, are required for the job at hand.

*\* at 1,400 rev/min with 16.9R34 tires and 12 x 12*



The left-hand Power Control lever provides convenient three-in-one, simple operation through the state-of-the-art transmission. Operators can shuttle between forward and reverse without clutching, making jobs that require frequent direction changes, like loader work, a breeze. Shuttle responsiveness can be modified by simply adjusting the comfort control dial.

## POWER CONTROL LEVER



All Global Series tractors come with a clutch control button on the gear shift for simple and clutch pedal-free gear shifting. To change gears in Global Series tractors, press and hold the clutch control button, shift to the desired gear, and let off the clutch control button.

## EASY SHIFT KNOB



Operators will find the Massey Ferguson clutch pedal is designed with the operator in mind. The design offers an easy-to-press pedal so operator fatigue is never an issue.

## EASY CLUTCH



# DYNA-2 POWERSHIFT TRANSMISSION

The Massey Ferguson 4700 Global Series tractors also has the option to be equipped with the Dyna-2 transmission, providing a total of twenty-four forward and reverse speeds, utilizing two ranges with six synchronized gears. The transmission allows the driver two gears clutchless, Hare & Turtle via an electric button on gear lever, or one rocker switch on the right carter.

24 forward and 24 reverse speeds ensure the correct gear for every job. Two Dyna-2 ratios provide a wide choice of speeds available under full load.

To operate the Dyna-2 transmission, a new control button has been added on the gear lever knob. The Dyna-2 can be activated from this button or the control switch on the right panel.

Left-Right: Brake to neutral, Speed Matching, Dyna 2 switch.

## DYNA-2 POWERSHIFT TRANSMISSION

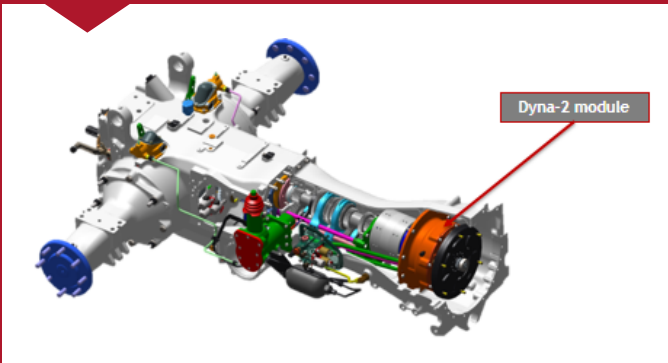

## NEW GEAR LEVER KNOB



## TRANSMISSION ROCKER SWITCHES



The Speed Matching provides the automatic selection of the appropriate Dyna-2 ratio when a gear change has been made. The speed matching feature minimizes driver effort and maximizes journey times.

Located on the right hand side console is the new break to neutral feature. Utilizing this feature will simultaneously operate the clutch as the brake pedal is pressed. This control enhances and eases loader operation as the operators needs to use just one pedal to brake and de-clutch at the same time.

## New Transmission and New Features:

- 24 Forward + 24 Reverse Gears
- 6 Synchronized Gears and 2 Ranges
- Power Shuttle, 2-Speed Powershift, & Speed Matching
- Brake to Neutral



# A TRACTOR THAT WON'T HOLD YOU BACK.

You've got a ton of different jobs to tend to each day, and the last thing you need is a feeble tractor that shies away from the really tough ones. The 4700, 5700 and 6700 Series are heavier than other tractors in their class, designed to handle larger, heavier implements and more demanding applications. So, yeah, they'll be there when you need them.

- **HEAVY-DUTY**—These three Series feature best-in-class base weight, and their heavier frames are purpose-built for more pulling power and lift capacity. With better maneuverability and more stability, you can rely on these tractors for even the most heavy-duty jobs.
- **THREE-POINT HITCH**—There's virtually no limit to the range of implements you can put behind these tractors. Two gear pumps power the simple, open-center hydraulic system, and a heavy-duty three-point hitch helps provide a rear lifting capacity ranging from 4,850 to 9,390 lbs.
- **PTO**—The 4700 Global Series tractors feature 540/540E PTO standard, with an option for the 540/1000 PTO.
- **TRELLEBORG TIRES**—Trelleborg premium radial tires come standard. Built exclusively for agricultural use, these tires provide better traction in the field, reduce soil compaction and improve fuel economy. Plus, the patented interlug terraces enhance self-cleaning in muddy soil. As a result, you enjoy a smoother ride and reduced wear on the tractor.
- **TELESCOPIC LOWER STABILIZING ARMS**—These heavier-duty stabilizing arms let you custom-adjust for any implement, for unmatched ease-of-use and greater control.
- **EXTENDABLE LOWER BALL ENDS**—Because extending the ball ends is as simple as pulling a ring on the link, implement attachment is always quick and easy.
- **2WD/4WD**—The 2WD axle option on all 4700 Series offers reduced weight and greater maneuverability, with five alternate track-width settings to accommodate your crop or field. Deluxe 4WD models feature the HydraLock, a hydraulic-controlled differential lock on the front axles. AutoLock and HydraLock are activated and deactivated via a rocker switch.
- **TIGHT TURNING RADIUS**—Sometimes you need to work in confined spaces. These tractors feature a tighter turning radius for easier maneuverability with better stability.
- **CAB**—The cab offered on all of our deluxe Global Series tractors is the largest and quietest cab within the utility tractor market.



**DESIGNED WITH YOU IN MIND.**





The 4700 Global Series are built for tough, demanding work in all kinds of environments. They are designed with simplicity of operation at their core and an emphasis on an operator environment that provides unmatched comfort. From the ground up, these tractors are engineered for smart, ergonomic, long-lasting operations.

- **GRAB RAILS**—Mounted outside the operator station for easy access into the tractor.
- **FLAT FLOOR**—MF 4700 Series models have a semi-flat floor.
- **EASY-REACH CONTROLS**—Essential controls are ergonomically positioned for easy operation and comfort.
- **ADJUSTABLE SEAT**—Cab tractors include a mechanical, swiveling seat standard, with an option for an air ride swiveling seat on 4700, while the air ride swivel seat is standard on 5700 and 6700. Platform Global Series tractors include a mechanical spring suspension seat.
- **INSTRUCTOR SEAT**—A second seat allows for an instructor and is standard equipment on the 4700 Series cab tractors.
- **TILT STEERING**—On cab models, a tiltable and telescopic steering column adjusts for maximum productivity and comfort. Platform is tilt only.
- **WORK LIGHTS**—Platform models include 4 headlights, 2 rear marker lights, 2 midmounted work lights, 1 rear work light and brake lights; while cab models include 4 headlights 2 midmounted work lights, 2 rear work lights, as well as rear marker and brake lights.
- **AND MORE**—Cupholders, metal toolbox and floor mat are standard on all models.



### WE'VE THOUGHT OF MOST EVERYTHING.

- **DASH DISPLAY**—The dash display includes a tractor performance monitor that provides data on DEF fluid level, fuel level, temperature range and more. Plus, you can monitor engine hours, acres per hour, fuel consumption per hour and per acre, fault codes, PTO speed, and ground speed with just the push of a button.
- **LOADER JOYSTICK**—Raise, lower, curl, dump or float the bucket with incredible precision, even in tight spots and tough applications. You'll appreciate the added integrated maneuverability.
- **DEBRIS SHIELD**—On platform models, shields on both sides of the operator station deflect engine heat and debris for additional protection and a comfortable working environment.
- **ADJUSTABLE WHEELS**—With a wide range of wheel-spacing settings, these tractors are versatile enough to handle everything from specialty farming applications, like small-scale row crops and vegetables, to roadside mowing and land-management applications.
- **LOADER FLOAT CONTROL**—Raise and lower the loader to the contour of the ground or road for the flexibility to efficiently handle grading and snow removal.
- **POWER SHUTTLE**—For loading trucks, stacking hay or other loader work, the power shuttle lever provides easy electrohydraulic declutch and directional changes without the need to press the foot clutch pedal.

# SPECIFICATIONS\*

MODEL	MF4707	MF4708	MF4709	MF4710
<b>ENGINE</b>				
Max engine power HP (kW) @ 2,000 RPM	75 (55.9)	85 (63.4)	95 (70.8)	100 (74.6)
Rated engine HP (kW)	70 (52.2)	80 (59.6)	90 (67.1)	100 (74.6)
Rated engine speed	2,200 RPM			
PTO HP (kW)	57 (42.5) @ 2,200 RPM 63 (46.9) @ 2,000 RPM	67 (49.9) @ 2,200 RPM 73 (54.4) @ 2,000 RPM	77 (57.4) @ 2,200 RPM 81 (60.4) @ 2,000 RPM	88 (65.6) @ 2,200 RPM 88 (65.6) @ 2,000 RPM
Engine	AGCO Power 3-cyl, 3.3 L, intercooled turbocharged, high-pressure common-rail direct fuel injection (HPCR)			
Emissions control; EPA Tier 4-compliant	Diesel Oxidation Catalyst (DOC), Exhaust Gas Recirculation (EGR)	SCR technology (post-combustion DEF), diesel oxidation catalyst (DOC)		
<b>DRIVETRAIN</b>				
Transmission type	12F x 12R, 2-range, power shuttle, electrohydraulic shuttle lever or opt. Dyna-2 powershift			
Clutch	Wet clutch with easy shift knob and electrohydraulic power shuttle lever			
Rear axle	Flange-type with internal planetary final drives			
Brakes	4 wheel disc brakes, independently controlled via foot pedals			
Differential lock	Rear axle engaged via electrohydraulic rocker switch			
Front axle	2WD or 4WD heavy-duty front axle			
<b>DIMENSIONS</b>				
Wheelbase in. (mm)	88.5 (2,250)			
Minimum width in. (mm)	Std. radial tires—rear 420/85R30, 60.3 (1,533)			
Base weight without ballast lbs. (kg.)	2WD ROPS: 7,478 (3,392); 2WD Cab: 8,294 (3,762) 4WD ROPS: 7,734 (3,508); 4WD Cab: 8,644 (3,921)			
Fuel capacity gal. (L)	27.7 (105), ground fill with metal fuel-tank guard			
<b>HYDRAULICS</b>				
Hydraulic system	Open center system, single pump			
Hydraulic flow @ rear remotes gpm (lpm)	17.7 (67)			
Rear remote valves	2 valves standard with (DA, KO, FL) 3rd valve optional with (DA, KO, FL, FD)			
Loader joystick	Optional integrated factory installed joystick			
3-pt. lift capacity lbs. (kg.) full stroke @ 24" (610 mm) behind ball ends	Category II, 4,850 (2,200)			
Rear PTO	Independent, electro-hydraulic engagement via switch, 540/540E Std., 540/1000 Opt.			
<b>OPERATOR'S AREA</b>				
Electrical system	12-volt DC system, 80-amp alternator, 7-pin trailer socket, 30-amp auxiliary power socket Std.			
Platform features	Semi-platform deck, folding ROPS, rubber mat, toolbox, L & R shields, grab handles			
Lighting (ROPS)	4 headlights, 2 rear signal/hazard lights, 1 rear ROPS work light; 2 mid-mount adjustable work lights			
Std. Steering	Cab = tilt and telescopic steering Platform = Tilt steering			
Std. Seat	MF 4700 Series cab = mechanical swiveling seat with armrests (air-ride swivel seat optional) MF 4700 Series platform = mechanical spring suspension seat with armrests			





## LOW-RATE, FLEXIBLE FINANCING.

With competitive rates and easy terms, your Massey Ferguson dealer and AGCO Finance® offer great ways to buy, lease or rent your new machine.

## QUALITY PARTS.



Genuine Massey Ferguson replacement parts are made to the same high standards as those used on the assembly line so you can always keep your Global Series tractor running like new.

## SHOW YOUR MASSEY FERGUSON PRIDE.

Choose from collectibles, toys, work and leisure wear, accessories and more. Visit [shopagco.com](http://shopagco.com) today.

## AGCO ANSWERS.

At AGCO, customer care isn't just a department. It's a commitment. We'll do our best to answer any questions promptly or put you in touch with someone who can. AGCO Answers: (877) 525-4384 or [agcoanswers@agcocorp.com](mailto:agcoanswers@agcocorp.com)



APPLY NOW FOR PRE-APPROVAL\*

[www.masseyferguson.us](http://www.masseyferguson.us)



or scan the QR code to get started.



For more than 25 years, in more than 140 countries worldwide, AGCO has been on a mission to become the single resource farmers can depend on for innovative, leading-edge thinking, equipment and technology. And, today, you know AGCO brands, even if you don't know the AGCO name. While AGCO equipment may not all share the same logo or same color, they all have one thing in common—the ability to help farmers be as productive and profitable as they possibly can be, regardless of the tasks at hand. [agcocorp.com](http://agcocorp.com)

MASSEY FERGUSON

FENDT



Challenger

GLEANER

We proudly support:

